



MAX FLOW SIZES
FROM 5 GPH to 20 GPM
(20 LPH TO 75 LPM)

MAX LIQUID PRESSURE 300 PSI (20.69 BAR)
MAX LIQUID PRESSURE 500 PSI (34.48 BAR)
MAX LIQUID PRESSURE 1500 PSI (103.45 BAR)

LL SERIES
LP SERIES
LH SERIES

Flow meters, Flow switches and Flow transmitters

A piston design for
low flows of liquids



LL Series, with standard scale and pointer (control box A).

CSA Certified NRTL/C

CE Marked (as noted)

NIST Traceable Calibration
Certificate Available

DESCRIPTION

These variable-area meters position an orifice over a tapered shaft to establish flow rate. Mounting is in-line and in any position. Straight pipe runs before or after this monitor are not required. The all-mechanical sensing system directly drives the pointer, switches and transmitters.

READOUTS

The flowmeter has outputs both visual and electronic. Visual displays are either pointer (with inscribed scale) or numeric (digital LCD). Electronic outputs can be mechanical switch closure, 4-20 mA analog or both (for signal redundancy). The switches can be general purpose or rated for hazardous locations (all classes, groups and divisions). The 4-20 mA transmitters are Intrinsically Safe if used with approved barriers.

CALIBRATION

All flow meters are individually calibrated for fluids with the viscosity you specify (up to 3000 SSU/650 Centistokes). We also compensate for your fluid's specific gravity. For NIST Traceability please consult factory.

CONSTRUCTION MATERIALS

Housings and seals are offered in a variety of materials to suit a wide range of applications, such as: water, oil, coolants, paint, solvents and some corrosive fluids. See selections in the "How to Order" section.

LINE CONNECTION

Ports can be threaded or flanged. See selections in the "How to Order" section.

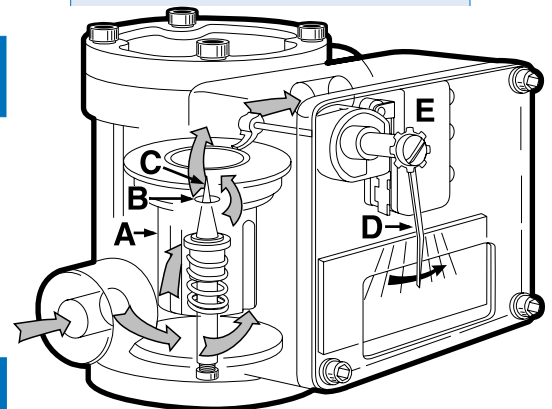

Fluid flow causes a spring-loaded piston **A** having a circular opening at its center **B** to move along the axis of a precision-tapered shaft **C**. This creates a variable orifice in direct proportion to the flow rate. The piston is mechanically linked to the readout pointer **D** and actuates switch **E** or a transmitter (not shown).

Viton® and Kalrez™ are registered trademarks for DuPont Performance Elastomers.

HOW TO ORDER Select appropriate symbols and build a model code number, as in example shown:

EXAMPLE: LL - B Z P S B 15GH- 4 U- 32ØV.9 -

SERIES BY PRESSURE RATING	
Normal pressure (150 or 300 PSI)	= LL
Medium pressure (500 PSI)	= LP
High pressure (1500 PSI)	= LH

HOUSING MATERIAL	WHERE USED		
Aluminum	Lube oil	=	A
Cast iron, nickel plated	Water, oil with exterior corrosion protection	=	N
Brass	Water	=	B
Cast iron	Oil	=	C
Carbon steel	Oil	=	M
Carbon steel, nickel plated	Water, oil with exterior corrosion protection	=	J
Stainless steel (316)	Chemicals, corrosives	=	Z

PISTON MATERIAL			
Brass	Water, oil	=	B
Stainless steel (316)	Corrosives, chemicals	=	Z

CAP MATERIAL		
Metal (same as housing) use matches housing (300 PSI)	=	M
Polysulfone (150 PSI)	=	P (LL only)

INTERNAL MOVING PARTS			
Stainless steel (300 series)	Standard for oil	=	S
Stainless steel (316 series)	Water, chemicals and corrosives	=	Z

SEAL MATERIAL			
Buna N	Water, oil	=	B
EPR	Hot water, caustics	=	E
Viton	Acids, some caustics	=	F
Kalrez	Corrosives, solvents	=	J
Kalrez (dynamic) & Buna N (static)	Specialty	=	A
Kalrez (dynamic) and EPR (static)	Specialty	=	H
Kalrez (dynamic) and Viton (static)	Specialty	=	K
Kalrez (dynamic) and Teflon (static)	Corrosives, solvents	=	T

(Available only in metal "Cap Material" (option M) = **T**)

MAX FLOW RATE LIQUIDS		
GPH: 5, 10, 15, 20, 25, 30, 40, 50, 60, 75, 80, 90, 100, 120, 150, 200, 250 & 300	=	GH
GPM: 0.25, 0.5, 0.75, 1, 1.5, 2, 2.5, 3, 4, 5, 6, 7, 8, 9, 10, 15 & 20	=	GM
LPH: 20, 30, 40, 50, 60, 70, 80, 90, 100, 200, 300, 400, 500, 600, 700, 800, 900 & 1000	=	LH
LPM: 5, 10, 15, 20, 25, 30, 35, 40, 50, 60, 70 & 75	=	LM
CMH: 1, 2, 3 & 4	=	CMH

THREADED ATTACHMENT						
Pipe size and attachment method	Pipe Size In Inches	NPT	SAE	BSPP	BSPT	Max Flow In GPM
	1/8	1	2T	2BP	2BT	2
	1/4	2	4T	4BP	4BT	5
	3/8	3	6T	6BP	6BT	10
	1/2	4	8T	8BP	8BT	15
	5/8		10T	10BP	10BT	15
	3/4	6	12T	12BP	12BT	20

FLANGED				
Ex: 2FWCS150RF = 1/4", Welded, Carbon steel, Class 150, Raised Face flange				
Pipe Size In Inches	Attachment	Material	Class	Style
2	= 1/4"	FW=Welded CS=Carbon Steel	150	RF=Ansi raised face
3	= 3/8"	FT=Threaded S=316 Stainless	300	
4	= 1/2"		600	
6	= 3/4"			
8	= 1"			

INLET PORT POSITION		
Upper inline (max. 2 GPM)	=	U
Lower offset	=	L

FLUID CHARACTERISTICS
 Viscosity number followed by a 'V' (for SSU), 'C' (for centipoise), or 'CS' (for centistokes) followed by the specific gravity. Example: **320V.9** would indicate a fluid with a viscosity of 320 SSU with a specific gravity of .9. For dual viscosities (where there is a start up viscosity or where there may be a range) put in both values with a slash. Example: 320/150V.9.

A1 W L - C - 5D

SERVICE

Oil and dust tight (Type 12) Available on "A", "L" and "Z" only = **N**
 Weatherproof (Type 4) Available on all boxes = **W**
 Weatherproof, corrosion proof (Type 4X) Available on all boxes = **X**

FLOW DIRECTION

Left to right = **R**
 Right to left = **L**
 Up = **U**
 Down = **D**

SPECIAL OPTIONS

High-temp- 400°F for A & R Box (300°F for transmitter options) = **HT**
 High accuracy (+/-3%) = **HA**
 Stainless steel ID tag = **ST**
 Pin connector with 3-6 pins, mini and micro style available = **PC**
 CSA enclosure / PVC window = **C**
 Tempered glass window = **TG**
 Wall mounting bracket = **W**
 Foot mounting bracket = **F**

SWITCH SETTING

No symbol = Lowest possible setting (usually 10% of maximum flow)
 Desired set point is assumed to be in flow units already selected (GPH). Give flow rate followed by a "D" for flow going down (flow failure) or a "U" for flow going up.
 Example, 5D indicates a setting of 5 GPH in declining flow. **5D**

CONTROL BOX & READOUT

Basic Features ↓	Additional Options ↓	Standard resolution pointer and inscribed scale			High resolution pointer and inscribed scale	Separate junction boxes (with terminal strips) for switch & transmitter
		"A", "L" and "Z" Box			"R" Box	"T" Box
		Materials of Construction				
		Polysulfone	Aluminum	316 Stainless	Aluminum	Aluminum
These options all include inscribed scale and pointer plus one of the standard (non hazardous location) switches selected to the right.	No switch	A0	L0	Z0	R0	
	One SPDT (3 wire), CE	A1	L1	Z1	R1	
	One high vibration SPDT (3 wire), CE	A1B	L1B	Z1B	R1B	
	Two SPDT (3 wire), CE	A2	L2	Z2	R2	
	Two high vibration SPDT (3 wire), CE	A2B	L2B	Z2B	R2B	
	One SPDT (4 wire)	A3	L3	Z3	R3	
	Two SPDT (4 wire)	A4	L4	Z4	R4	
	One SPDT (3 wire) high temperature	A61	L61	Z61	R61	
	Two SPDT (3 wire) high temperature	A62	L62	Z62	R62	
	One SPDT (3 wire) gold contact	A71	L71	Z71	R71	
Two SPDT (3 wire) gold contact	A72	L72	Z72	R72		
These options all contain inscribed scale with pointer plus hazardous location switches selected to the right. Note that the box is not rated, only the switches.	One SPDT hazardous location (all classes, groups and divisions)				R7	
	One DPDT hazardous location (all classes, groups and divisions)				R17	
	Two SPDT hazardous location (all classes, groups and divisions) Available with flows ≥ 2 GPM				R18	
	Two DPDT hazardous location (all classes, groups and divisions) Available with flows ≥ 2 GPM				R19	
	One SPST hazardous location proximity (all classes, groups and divisions)				R30	
	Two SPST hazardous location proximity (all classes, groups and divisions)				R31	
	One SPDT (3 wire) hermetically sealed	A53	L53	Z53		
Two SPDT (3 wire) hermetically sealed	A54	L54	Z54			
These options all contain a 4-20 mA transmitter and one of the selections to the right.	No switches (Intrinsically safe with barrier)	AX0	LX0	ZX0	RX0	TX0
	One SPDT (3 wire), CE				RX1	TX1
	Two SPDT (3 wire), CE				RX2	TX2
	One SPDT (4 wire)				RX3	TX3
	Two SPDT (4 wire)				RX4	TX4
	One SPDT (3 wire) high temperature				RX61	TX61
These options all include a 4-20 mA transmitter with a digital LCD display plus one of the selections to the right.	No switches					TXL0
	One SPDT (3 wire), CE					TXL1
	One SPDT (4 wire)					TXL3
	One SPDT (3 wire) high temperature					TXL61

ENGINEERING DATA

Maximum fluid temperature: 200°F (93°C)

Optional max. fluid temperatures: 300 & 400°F (148 & 204°C) (option HT)

Maximum ambient temp: 150°F (65°C) CSA listed only to 105°F (41°C)

Series LL max. operating pressures:

With plastic cap: (3:1 safety factor): 150 PSI (10.34 BAR)

With metal cap: (3:1 safety factor): 300 PSI (20.69 BAR)

Series LP max. operating pressures: (2:1 safety factor): 500 PSI (34.48 BAR)

Series LH max. operating pressures: (2:1 safety factor): 1500 PSI (103.45 BAR)

Pressure drop: 5 PSI (.35 BAR) at full scale

Readout accuracy, full scale: ±5%

Switch repeatability is 1% of actual flow

INSTALLATION

Flow monitors mount in-line or offset and are typically supported by rigid pipe. For additional support when using tubing or flexible hose, order special options **W** (wall) or **F** (foot) mounting brackets.

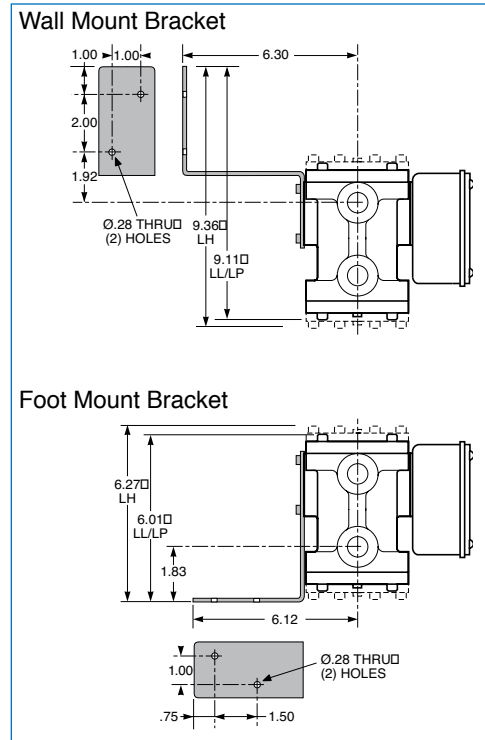

SPECIAL OPTIONS

High temperature: (option HT) requires all-metal construction (M Cap material) with seals of Viton, EPR, Kalrez or Teflon (compatible with fluid). A thermal barrier (heat-resistant cloth) is added between the housing and the control box, which must be used with service option "W" (weatherproof) or "X" (corrosion resistant). A metal scale is provided.

High Accuracy: (option HA)

Modification of full scale to +/-3%. HA not available with transmitter or R7, R17, R18, R19 switch options. Requires flow rates of 1 GPM or greater.

Identification tag: (option ST) customer-supplied information is stamped on a stainless steel tag that is attached to the nameplate.

Multi-pin connector: Pin connectors (option PC) are available for rapid field installation. Meters are provided with the male half of either a micro or a mini pin connector. Check the chart below for the number of pins required for your control box selection and current type. Insert the number of pins in the code PC__ for a

mini connector or PC__M for a micro connector. For example, a PC5 would be a 5 pin mini and PC5M would be a 5 pin Micro. (See table below for number of pins required for each option.)

Tempered-glass window: (option TG) replaces the standard window. A tempered-glass window is employed where airborne solvents or high-ambient temperatures are common.

Number of pins required for various combinations of current type, box type and switch option.

Box	AC switch options			1, 1B, 61, 71		3		53
	DC switch options	0	1, 1B, 61, 71	3	2, 2B, 54, 62, 72		53	
A			3	4	6	5	3	4
R			3	4	6	5	3	4
RX	3							
TX	3	3		4			3	4
TXL	3	3		4			3	4

*This box allows micro pin connectors only. Eg. PC3M or PC5M.

CONTROL BOX SELECTION GUIDE

“A”, “L” and “Z” Boxes

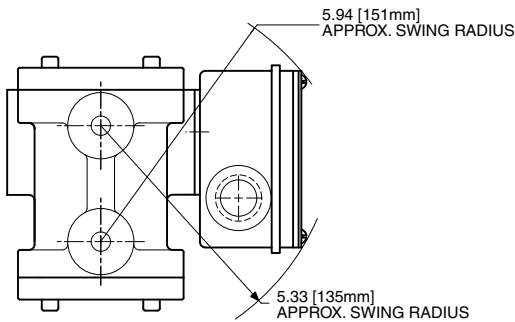

“A” box is selected for price and simplicity.

It holds switches (general purpose and hermetically sealed) or 4-20mA transmitter.

You get this control box when you order any CONTROL BOX & READOUT starting with an “A” (see "How to Order" page).
Examples: A1WR is a one switch, weatherproof box with flow from left to right.

This control box is made of Polysulfone (standard low cost “A”) with options for aluminum (“L”) or 316 stainless steel (“Z”).

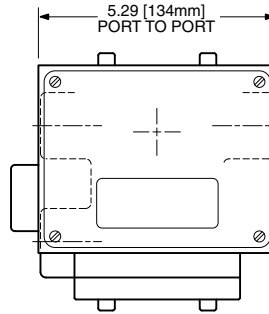

Maximum installation dimensions

“R” Box

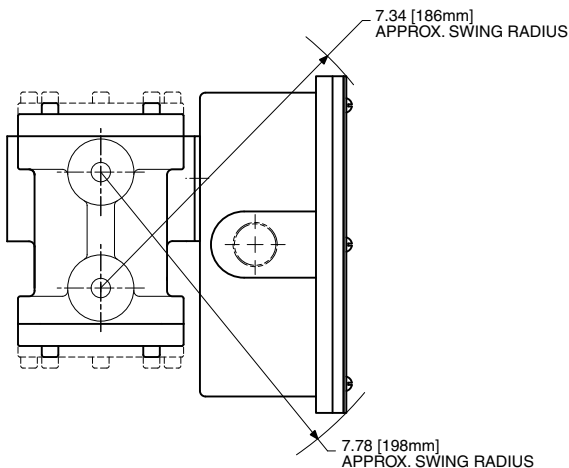

“R” box is selected for greater resolution (more increments on the inscribed scale).

It holds switches (general purpose and hazardous location all classes groups and divisions) and 4-20mA transmitter. Switch (standard service) and transmitter are offered in this control box together when signal redundancy is desired.

You get this control box when you order any CONTROL BOX & READOUT starting with an “R” (see "How to Order" page).
Examples: R1WR is a one switch, weatherproof box with flow from left to right.

This control box is made from epoxy coated aluminum.

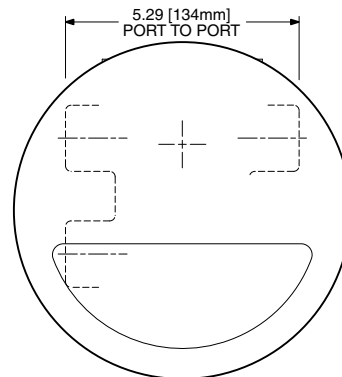

Maximum installation dimensions

CONTROL BOX SELECTION GUIDE

“T” Box



“T” box is selected for availability of two isolated junction boxes with terminal strips. This means that no direct wiring to switches or transmitters is required.

Digital LCD display of flow is optional (“TXL”).

It holds switches (general purpose) and 4-20mA transmitter. Switch (standard service) and transmitter are offered in this control box together when signal redundancy is desired. These are wired to separate junction boxes for signal isolation.

You get this control box when you order any CONTROL BOX & READOUT starting with a “T” (see "How to Order" page). Examples: TX1WR is a one switch with 4-20mA transmitter, weatherproof box with flow from left to right.

This control box is made from epoxy coated aluminum.

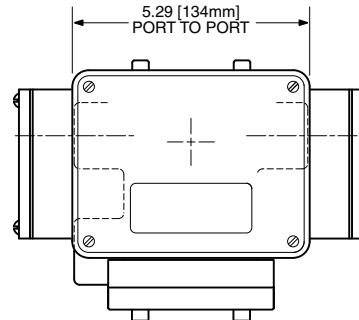
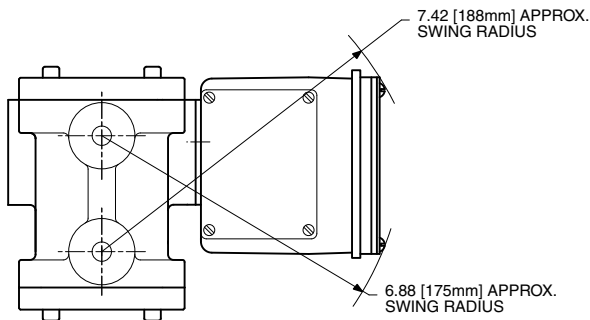

Maximum installation dimensions

Flanged Face to Face Dimensions for In-Line and Offset Installation

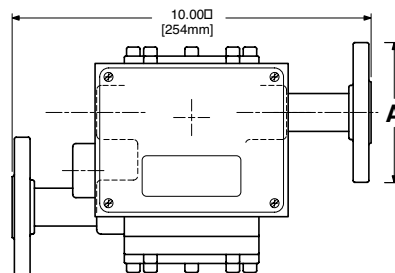
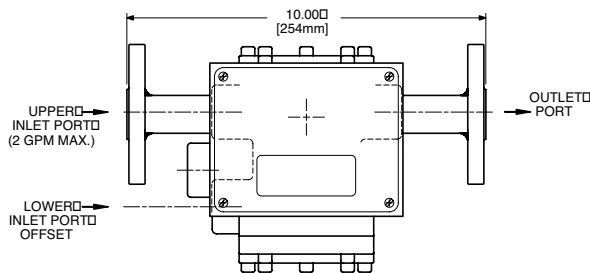

With 150 lb R.F. flanges
(for other flanges consult factory)

Port Size (inches)	A (inches)
1/2	3.50
3/4	3.88
1	4.25



Universal Flow Monitors, Inc.

1755 E. Nine Mile Road ▪ P.O. Box 249 ▪ Hazel Park, MI 48030

Tel: 248-542-9635 ▪ Fax: 248-398-4274

www.flowmeters.com ▪ E-mail: ufm@flowmeters.com