

**MODEL-Q2**  
Direct Mounted 2-Valve  
Transmitter Manifold  
Rated 413 BAR / 6000 PSI

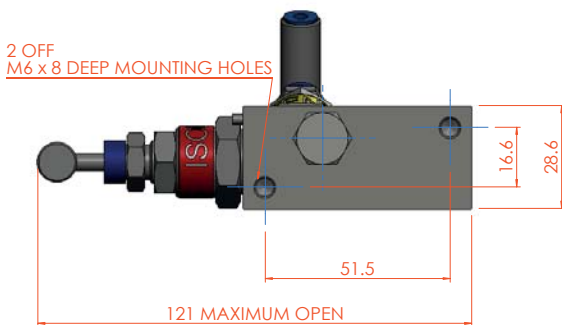

**SCHEMATIC**

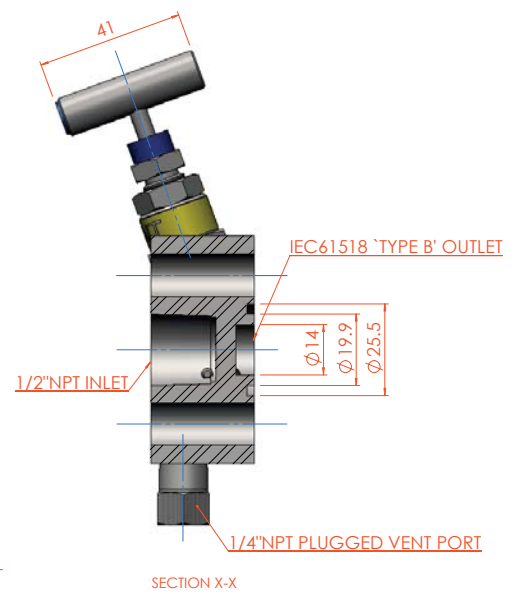
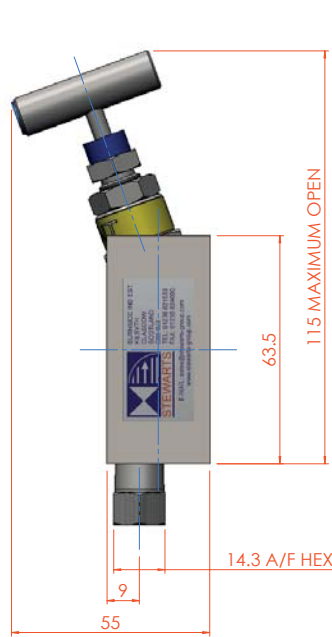
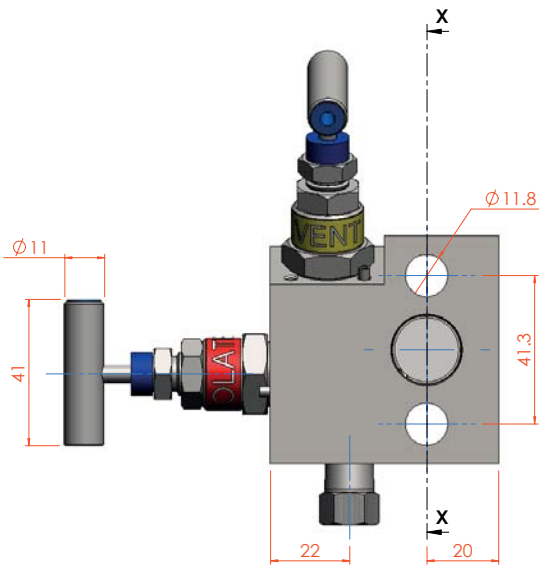
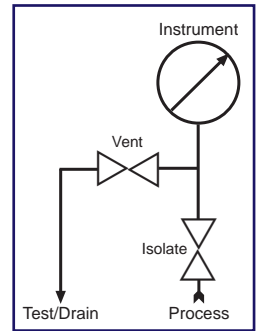

MANIFOLD IS SUPPLIED COMPLETE WITH  
2 OFF 45mm LONG 7/16-20 UNF ST/ST TRANSMITTER MOUNTING BOLTS  
AND 1 OFF PTFE FLAT SEALING RING.